

# TORS

Torsional Orthopaedic Revision System

## User Manual



CONTENTS

CONVENTIONS USED IN THIS DOCUMENT ..... 4

*Warning:*..... 4

*Caution:*..... 4

CONTACT INFORMATION ..... 4

INTENDED USE / PURPOSE ..... 5

INTENDED USER ..... 5

TARGET POPULATION ..... 5

CLINICAL BENEFIT ..... 5

PLEASE NOTE: ..... 5

INDICATIONS ..... 5

CONTRAINDICATIONS ..... 5

**THE TORS SYSTEM ..... 6**

    OVERVIEW ..... 6

    GENERATOR ..... 6

*Front Panel* ..... 6

*Rear Panel* ..... 6

*TORS Transducers & Cables* ..... 7

    TORS (SERIES 1) PARTS LIST ..... 8

**SAFETY  ..... 9**

    WARNINGS ..... 9

    CAUTIONS ..... 10

    ELECTROMAGNETIC INTERFERENCE ..... 10

    COMPLICATIONS AND POTENTIAL SIDE-EFFECTS ..... 11

    SERIOUS INCIDENT ..... 12

**INSTRUCTIONS FOR USE ..... 13**

    SETTING UP THE TORS SYSTEM ..... 13

*Power up the Generator* ..... 13

*Optional - Attach the "Cement" footswitch to the Rear Panel* ..... 13

*Attach the "Soft Tissue" footswitch to the Rear Panel* ..... 13

*Assemble the Cement Transducer + Probe (Applied Part)* ..... 13

**ARCHIVED COPY:**  
**DO NOT USE**

<i>Optional - Attach the Soft Tissue Transducer (Applied Part)</i> .....	14
<i>Cement Transducer - Connect</i> .....	15
<i>Cement Transducer - Initialise</i> .....	15
<i>Cement Transducer - Activate</i> .....	15
<i>Cement Removal Irrigation</i> .....	16
<i>Fume Extraction</i> .....	16
<i>Soft Tissue Transducer - Connect</i> .....	16
<i>Soft Tissue Transducer - Irrigate</i> .....	16
<i>Soft Tissue Transducer – Change Power Level</i> .....	17
<i>Soft Tissue Transducer – Activate</i> .....	17
<i>Performance Characteristics</i> .....	18
<i>Turn Off TORS</i> .....	18
<i>FAULT / WARNING INDICATORS: (SEE ALSO APPENDIX 4: TONES AND BEEPS)</i> .....	19
<b>DECONTAMINATION</b> .....	<b>21</b>
• <i>After Use Re-Processing</i> .....	21
• <i>Single Use Items</i> .....	21
• <i>Reusable Items</i> .....	22
○ <i>MANUAL CLEANING</i> .....	22
○ <i>AUTOMATED CLEANING</i> .....	22
• <i>CLEANING INSPECTION</i> .....	22
• <i>WRAPPING</i> .....	22
• <i>STERILIZATION</i> .....	22
• <i>End of Life Management</i> .....	23
• <i>Opened in Error</i> .....	23
• <i>Cleaning the Generator</i> .....	23
• <i>Cleaning the Footswitch</i> .....	23
<b>EQUIPMENT CARE</b> .....	<b>26</b>
<i>Probe Inspection</i> .....	26
<i>Transducer / Probe Usage</i> .....	26
<i>Storage of Equipment between Cases</i> .....	27
<i>Maintenance</i> .....	27
<i>Technical Support</i> .....	27

**ARCHIVED COPY:  
DO NOT USE**

<b>APPENDICES .....</b>	<b>28</b>
APPENDIX 1: MARKINGS ON THE TORS FRONT AND BACK PANELS .....	28
APPENDIX 2: LABELLING SYMBOLS GLOSSARY .....	30
APPENDIX 3: ELECTROMAGNETIC INTERFERENCE .....	37
APPENDIX 4: TONS UNIT BEEPS .....	39
APPENDIX 5: REAR PANEL MESSAGES .....	40
APPENDIX 6: TECHNICAL SPECIFICATION.....	40
APPENDIX 7: WARRANTY STATEMENT .....	41

**ARCHIVED COPY:**  
**DO NOT USE**

**Conventions used in this document**

**Warning:**



A statement that if not strictly followed could result in injury or loss of life, or a statement that is otherwise required to be a warning.

**Caution:**

A statement that if not strictly followed could result in damage to the equipment

**Contact Information**

If the unit requires repair please contact us through your local supplier or directly:

Radley Scientific Ltd.  
Bremridge House  
Bremridge  
Ashburton  
S. Devon  
TQ13 7JX  
UK

Tel: +44 (0)1364 653899

[www.tors.co.uk](http://www.tors.co.uk)

## Intended Use / Purpose

TORS is an ultrasonic surgical device intended to be used for removal of polymethylmethacrylate (PMMA) bone cement in orthopaedic applications. It is also intended to be used for cutting and cauterising soft tissue during skin and muscle incision to access bone joints in limbs.

## Intended user

TORS is intended to be used by surgical staff experienced with the operation of ultrasonic devices for cement removal and haemostatic tissue incision, in a professional clinical setting. See relevant Warnings.

## Target Population

The functions of TORS are specific to the revision of cemented joint implants, cement removal from the bone cavity and soft-tissue cutting to provide mobilization of the joint. Applicable joints are hip, knee, shoulder and elbow. There are no specific restrictions based on age, weight, health status or ethnicity. Whilst no specific patient populations have been defined, patients with contraindication are to be excluded, see Contraindications.

## Clinical Benefit

1. During treatment with TORS, the patient benefits from the combination of two functions in one device: ultrasound bone cement removal and tissue coagulation/cutting.
2. **TORS is a state-of-the-art device for effective cement removal in orthopaedic revision surgeries.** It provides clinical benefit over mechanical cement removal methodologies through reduced risk of perforation compared to conventional **mechanical** methods.
3. The soft tissue mode allows cutting and cauterization with ultrasound which deploys mechanical vibration to cauterize at lower average temperature than electrosurgical knives.

## Please note:

- This document does not reference surgical techniques.
- The safety & effectiveness of any ultrasonic surgical equipment is mostly dependent upon the surgeon and nursing staff.

## Indications

TORS is indicated for use in the removal of polymethylmethacrylate (PMMA) bone cement in orthopaedic applications. It is also indicated for soft tissue surgical incisions when bleeding control and minimal thermal injury are important.

## Contraindications

- Do not use, if in the judgment of the surgeon, the use of ultrasonic surgical techniques are not in the best interest of the patient.
- Do not use for incising bone.
- The Soft tissue transducer is not indicated for the cutting of vessels exceeding 1.5mm in diameter or bone tissue.

**Please read all Warning & Cautions contained in this document**

## The TORS System

### Overview

TORS 1, Torsional Orthopaedic, Revision System Series 1, is an integrated ultrasonic device, combining the two modalities of ultrasonic PMMA cement removal and unique torsional mode ultrasonic soft tissue coagulation and dissection, to provide a single platform for state of the art performance and convenience in arthroplasty surgery, especially cemented joint revision. The system comprises a multichannel console that provides twin Cement channels and one Soft Tissue channel. The former allow rapid probe interchange by the surgeon as well as 100% redundancy in case of damage/contamination. A full set of reusable Piercer and Scraper probes is available for the surgeon to choose from. The Soft Tissue channel enables low temperature, low smoke emission, cauterizing and division of subcutaneous muscle and fat during the joint access phase, potentially replacing electric current, pacemaker-prohibited, diathermy. All parts except the single use, ergonomic, 360° finger-switch, plastic handpiece on the Cement Transducers are washable, autoclavable and reusable.

### Generator

#### Front Panel

The screen is highly visible, especially in a darkened operating theatre, indicates operating mode selected and gives concise instructions on action required in the event of disruption to normal operation.

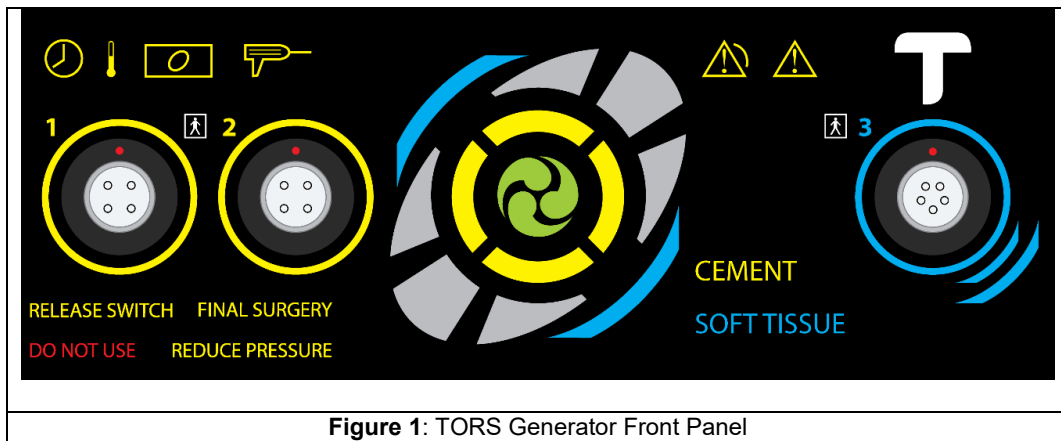

Figure 1: TORS Generator Front Panel

#### Rear Panel

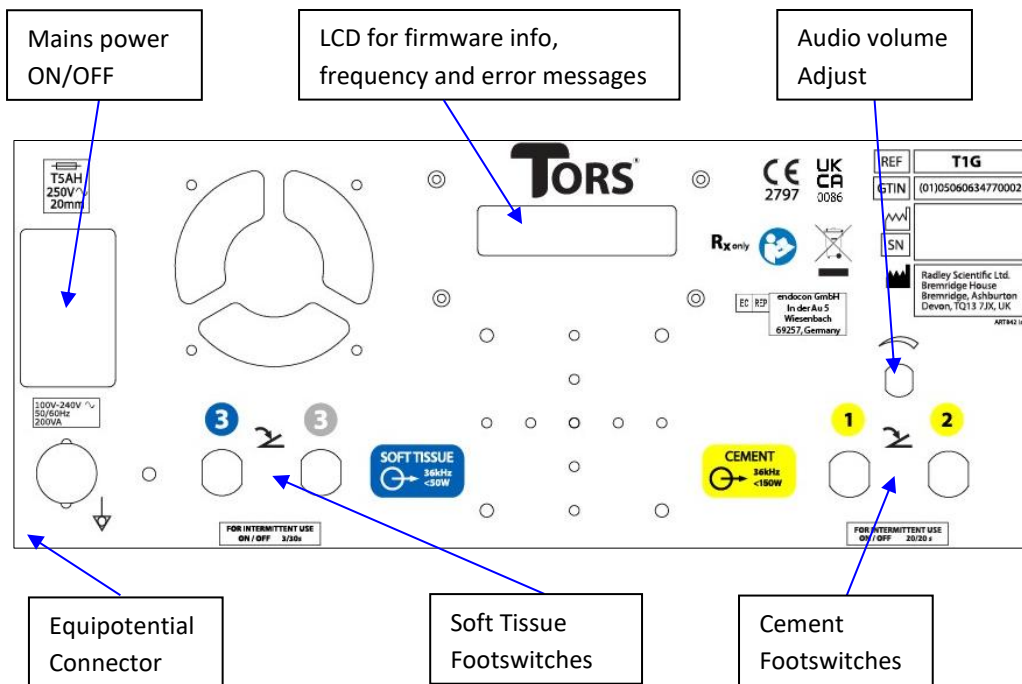

Figure 2: TORS Generator Rear Panel

There is only one user control on the Generator itself:

- Volume control (on the rear panel)

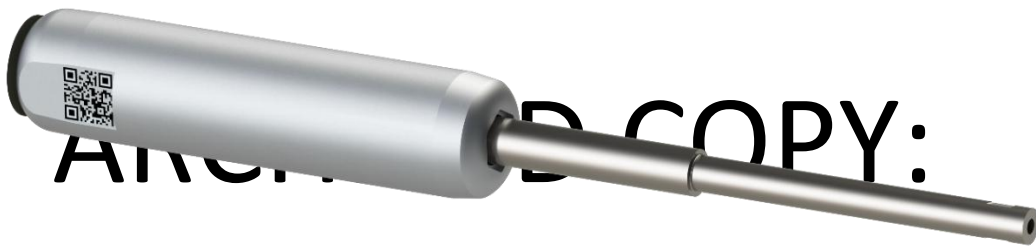

Figure 3: TORS Cement Transducer

**DO NOT USE**



Figure 4: TORS Soft Tissue Transducer + Probe



Figure 5: Cement Cable

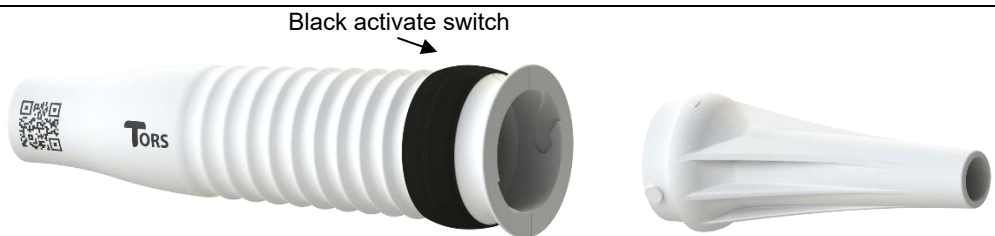

Figure 6 – Axial Grip Handpiece



Figure 7 – Axial Grip Handpiece with Cement Transducer, Probe, and Cement Cable fitted

## TORS (Series 1) Parts List

ITEM	Product Code	UDI-DI
Cement Axial Grip Handpiece (Single Use)	T1AH	05060634770323
Cement 200 Ø4 Piercer Probe (Reusable)	P4R2	05060634770729
Cement 200 Ø6 Piercer Probe (Reusable)	P6R2	05060634770736
Cement 200 Ø8 Piercer Probe (Reusable)	P8R2	05060634770743
Cement 200 Ø10 Piercer Probe (Reusable)	P10R2	05060634770750
Cement 200 Ø6 Scraper Probe (Reusable)	S6R2	05060634770767
Cement 200 Ø8 Scraper Probe (Reusable)	S8R2	05060634770774
Cement 200 Ø10 Scraper Probe (Reusable)	S10R2	05060634770781
Probe Extension Bar - Straight (Reusable)	ESR1	05060634770989
Probe Extension Bar - Curved (Reusable)	ECR1	05060634770996
Soft Tissue Transducer + Probe (Reusable)	T1TT	05060634770088
Cement Transducer (Reusable)	T1CT	05060634770064
Cement Cable (Reusable)	T1CC	05060634770071
Generator	T1G	05060634770002
Mains Power Cordset	MPC	05060634771016
Generator Carry Case	T1GC	05060634770040
Cement Footswitch	T1FC	05060634770019
Soft Tissue Footswitch	T1FT	05060634770026
Autoclave Tray	T1AT	05060634770095
Autoclave Tray Mat	T1SM	05060634770101
Instrument Carry Case	T1IC	05060634770118
Spanner	T1S	05060634770354
Probe Cleaning Cell	T1CW	05060634770279

### Optional Extras

Cement 100 Ø6 Piercer Probe (Reusable)	P6R1	05060634770927
Cement 100 Ø8 Piercer Probe (Reusable)	P8R1	05060634770934
Cement 100 Ø6 Scraper Probe (Reusable)	S6R1	05060634770941
Cement 100 Ø8 Scraper Probe (Reusable)	S8R1	05060634771047
Probe Extension Bar - Long - Straight (Reusable)	ESR2	05060634770972

## Safety

### Warnings

- This device should only be used by surgeons who are (1) trained in the types of surgical procedures that are to be carried out and (2) trained in the specific use of ultrasonic surgical instruments.
- Do not operate TORS in a potentially explosive or flammable area, or in oxygen rich environments. Note that if the Probe touches anything metal, while active, sparks may be produced.
- The use of TORS in cases where a patient or the operator of the unit has been fitted with a cardiac pacemaker is left to the discretion of the consultant in charge of the procedure although no electrical flow is made through or into the patient and many clinical papers on the use of ultrasound in the proximity of cardiac pacemakers have been published.
- Appropriate protective measures, including smoke evacuation, should be taken to protect users from any smoke, or other aerosols, produced by the use of surgical ultrasound.
- Use extreme caution when using in the vicinity of nerves.
- Handle reusable parts correctly in order to achieve full service-life.
- Do not attempt to modify the acoustics. No modification of this equipment is allowed.
- The use of transducers or handpieces not supplied as part of the TORS system may damage the Generator and create a safety hazard for the operator and patient.
- Avoid touching or holding the probe tip at the end of the active probe. Danger of burns!
- Other than the active tip, do not allow probe to be in contact with tissue.
- Irrigate the femoral canal after each activation.
- If the probe is deactivated inside heated PMMA it is possible the cooling cement will adhere very strongly to the probe, in which case it may become difficult to reactivate the probe in order to remove it from the cement.
- When guiding the TORS Cement Probe through PMMA, care must be taken not to exert excessive force in order to maintain control of the direction of travel of the probe.
- Use of excessive force in vicinity of thin bone may cause perforation.
- Avoid resting the hot probe tip on skin or other tissue for at least 60 s after cessation of energizing as it will have become hot while cutting. (User may quench hot probe tip / blade in saline.)
- Care should be taken when in contact with tissue between activations, in case accidental activation should occur.
- If the probe comes into contact with bone, using recommended cooling strategies a bone temperature of up to 51°C may be seen.
- Allowing active tip to contact bone may cause damage to the bone.
- Wherever possible avoid contact between the side of active cement probe and patient tissue.
- Mains isolation is achieved by use of the double pole switch located on the rear panel. DO NOT position the equipment in such a way as to make access to this disconnection switch difficult.
- To avoid the risk of electric shock, this equipment must only be connected to a main's supply with protective earth.
- TORS is not MRI safe or MRI compatible.
- Do not re-sterilize or reuse any single use parts.
- Portable RF communications equipment (including peripherals such as antenna cables and external antennas) should be used no closer than 30 cm (12 inches) to any part of TORS, including cables specified by RSL. Otherwise, degradation of the performance of this equipment could result.
- TORS should not be used adjacent to or stacked with other equipment. If adjacent or stacked use is necessary TORS should be observed to verify normal operation in the configuration in which it will be used.
- The use of accessories, transducers and cables other than those specified may result in increased emissions, decreased immunity or improper operation.
- There are no user serviceable parts.
- Do not combine multiple extension bars, only use one extension bar per cement probe and transducer.
- When attaching cement probes to the cement transducer, do not OVER-TIGHTEN the probe, a firm pressure applied with both spanners, is all that is required.

## Cautions

- U.S. law restricts this device to sale by or on the order of a licensed physician.
- The nursing staff must be trained so that they are familiar with the equipment to be used.
- Before any sterile packed (single use) accessory for TORS is opened, it must be inspected for packaging integrity. The outer carton may be dented, crumpled or even punctured, so long as the sealed pouch inside is not punctured. If a bend or wrinkle in the pouch makes puncture likely DO NOT OPEN/USE but return to manufacturer.
- Avoid allowing an active probe to come into contact with any metal surface. Any damage increases the risk of fatigue, which might result in tip detachment from the probe.
- Do not sterilize the TORS generator or footswitch.
- Do not allow the generator to enter the sterile field in theater.
- Do not block or otherwise restrict the vents on the rear and bottom panels of the generator.
- Never allow electrosurgical equipment to contact the probe.
- Do not spill any liquid upon the generator.
- Ensure that more than one single use axial-grip handpiece is available in case of accidental contamination.
- Always transport TORS using the supplied transport cases.
- The TORS generator has an Equipotential Terminal on the back panel. This is provided for compatibility with other medical systems requiring such connections. This conductor is not intended for protective earthing. Refer to EN 60601-1 for details of use with ME Systems.
- TORS:
  - i. should be used only for those procedures for which it is indicated.
  - ii. should be used with an appropriate power level commensurate with the required task.
  - iii. should be used with correct surgical technique.

If used correctly the TORS should cut and coagulate tissue and remove PMMA cement to the satisfaction of the user.

The equipment should inform the user of its status either by audio or visual means, unless ultrasound output is not possible. However, if a fault with the audio or visual indicators occurs whilst a cut is in progress, it may allow that cut to be completed without indication.

## Electromagnetic Interference

- This equipment is only suitable for use in hospital operating theatre / operating room.
- The performance of TORS may be degraded if it is subjected to electromagnetic disturbances e.g. an incorrect display that clears automatically once activate switch is pressed/depressed.
- Do not use TORS simultaneously with laser equipment or high frequency surgical equipment.
- This equipment has been tested and found to comply with the limits for a medical device.

However should interference occur, the user can try the following measures:-

1. Turn equipment off and on to confirm the source of the interference.
  2. Increase separation between this equipment and other devices.
  3. Connect this equipment to a power socket different from that to which the other devices are connected.
  4. Consult medical physics department.
- The EMISSIONS characteristics of this equipment make it suitable for use in industrial areas and hospitals (CISPR 11 class A). If it is used in a residential environment (for which CISPR 11 class B is normally required) this equipment might not offer adequate protection to radio-frequency communication services. The user might need to take mitigation measures, such as relocating or re-orienting the equipment.
  - Where replacement transducers and cables are required, these must be manufactured by RSL (see Appendix 2 for full listing),

- See also
- Appendix 3: Electromagnetic Interference.

## Complications and Potential Side-effects

### General risks and complications of arthroplasty surgery

- Bone loss during prosthesis and/or cement removal
- Cortical perforation
- Fracture in the bone around the artificial joint
- Recovery time, pain and potential for arthritis associated with deliberate osteotomy
- Nerve/vascular lesions
- Rebleeding or haematoma/seroma
- Ligament, arterial or nerve damage in the area around the knee joint
- Blood clots or deep vein thrombosis or pulmonary embolism
- Haemorrhage caused by tissue injury or ineffective haemostasis
- Bone/joint infection
- Late infection
- Infection of the wound and/or the tissue around the artificial joint
- Thromboembolism
- Implants or metal parts remaining in joint
- Fatigue fracture
- Excess bone forming around the artificial joint (knee) restricting movement
- Excess scar tissue forming and restricting movement
- Kneecap or hip dislocation
- Numbness in the vicinity of the wound scar
- Loosening of the artificial joint (normally after 10-15 years)
- Joint wear and tear
- Joint stiffening
- Bone cement implantation syndrome
- Hypoxia
- Hypotension
- Cardiac arrhythmias
- Cardiovascular collapse
- Thermal injury due to cement polymerization (setting) reaction
- Contact inhalational exposure to PMMA monomer leading to hypersensitivity
- Asthmatic reactions
- Neurological symptoms
- Localized irritation
- Personal risks from anesthetic or the surgery itself

### Potential side-effects of ultrasonic arthroplasty surgery

- Necrosis and clinical dysfunction in femoral cortex and surrounding soft tissue due to heat transmission from ultrasonic probe/cement interface
- Intramedullary canal perforation
- Different tissues and bone cement will be heated to different degrees with the same ultrasound parameters

- Each cell type has a different susceptibility to thermal injury
- Pathologic humeral fracture
- Microscopic bone cracks
- Plume production (95% water, 5% cell debris)
- Nerve palsy
- Risk of cross-infection from re-sterilized reusable parts of the system
- Weakening of the remaining cortical bone
- Incomplete extraction of the cement
- Cement removal occurs more slowly than expected

**ARCHIVED COPY:**

**DO NOT USE**

General complications of powered dissection in open soft tissue surgery

- Acute or delayed bleeding (blood loss), organ perforation or fistula formation
- Haemorrhage caused by tissue injury or ineffective haemostasis
- Necrosis due to excessive heat transmission from the dissector
- Infections at the site of application
- Nerve lesions/damage

Potential side-effects of ultrasonic powered dissection in open soft tissue surgery

- Necrosis in soft tissue due to cavitation/shock waves or excessive heat from ultrasonic probe
- Visibility reduction due to plume production (95% water, 5% cell debris) or smoke production
- Risk of transmission of mutagenic or toxic chemicals in the plume
- Risk of cross-infection from re-sterilized reusable parts of the system
- Device breakage and loss of components in the body cavity

## **Serious Incident**

The Medical Device Regulation defines a serious incident as:

“...any incident that directly or indirectly led, might have led or might lead to any of the following:

- (a) the death of a patient, user or other person,
- (b) the temporary or permanent serious deterioration of a patient's, user's or other person's state of health,
- (c) a serious public health threat”

In the event that a serious incident occurs in relation to the TORS device, the user and/or patient should report the serious incident to the Manufacturer and to the Competent Authority of the state in which the user and/or patient is established.

## Instructions for Use

Note. Neither the generator nor any other component accessory of this device can be connected to an external network of any kind; no external connection ports of any type are provided upon the generator. In this context no minimum hardware requirement exists, since the user has no ability to gain unauthorized access to the firmware.

## Setting Up the TORS System

Remove the protective film from the generator front panel, if it remains attached.

### Power up the Generator to

- Connect the mains lead to the rear panel of the Generator.
- Press the Mains rocker switch up, "I", to switch on.
- The Generator will now power up with an audio indicator flourish of tones, conduct a brief full screen illumination test as shown in Figure 8.

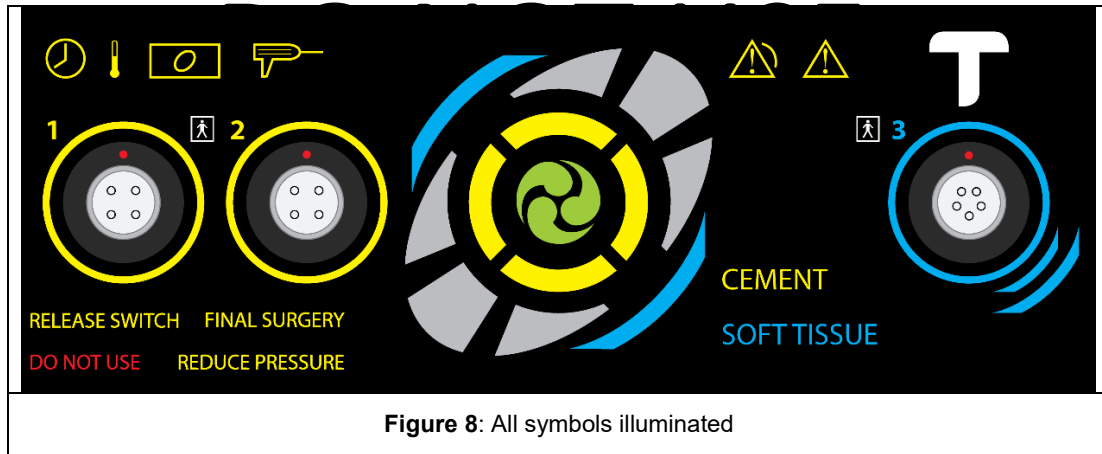

- After approximately one second the display will show:

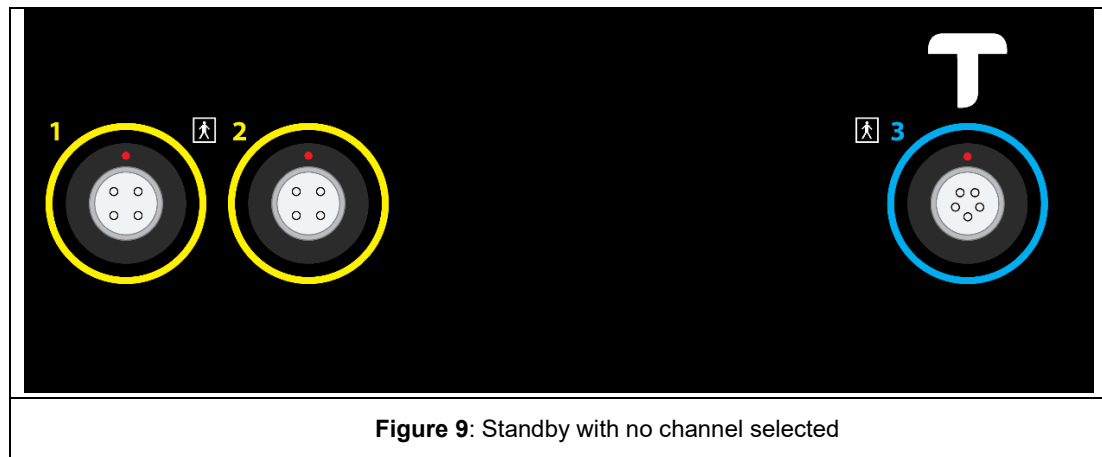

### Optional - Attach the "Cement" footswitch to the Rear Panel

- The tube with the **Yellow** + "1" collar attaches to the similarly marked connection.
- The tube with the **Yellow** + "2" collar attaches to the similarly marked connection.

### Attach the "Soft Tissue" footswitch to the Rear Panel.

- The tube with the **Grey** + "3" collar attaches to the similarly marked connection.
- The tube with the **Blue** + "3" collar attaches to the similarly marked connection.

### Assemble the Cement Transducer + Probe (Applied Part)

- Select the pre-sterilized cement transducer.

- Select the appropriate pre-sterilized reusable probe.
- Select the sterile axial-grip handpiece (single use).
- Fit the transducer into the handpiece. Rotate the transducer and drop into place – ensure that it is securely connected. See (1) & (2) in Figure 10 below.
- Slide the handpiece sleeve over the Transducer horn. Locate the lugs at the base of the sleeve into the handpiece grip and twist / click into place. See (3) below.
- Using both supplied spanners, attach the probe to the transducer (4) & (5) below.
- **ALWAYS use BOTH spanners for tightening the probe to avoid damaging the cement transducer.**
- **Do not OVER-TIGHTEN the probe.**

**ARCHIVED COPY:**

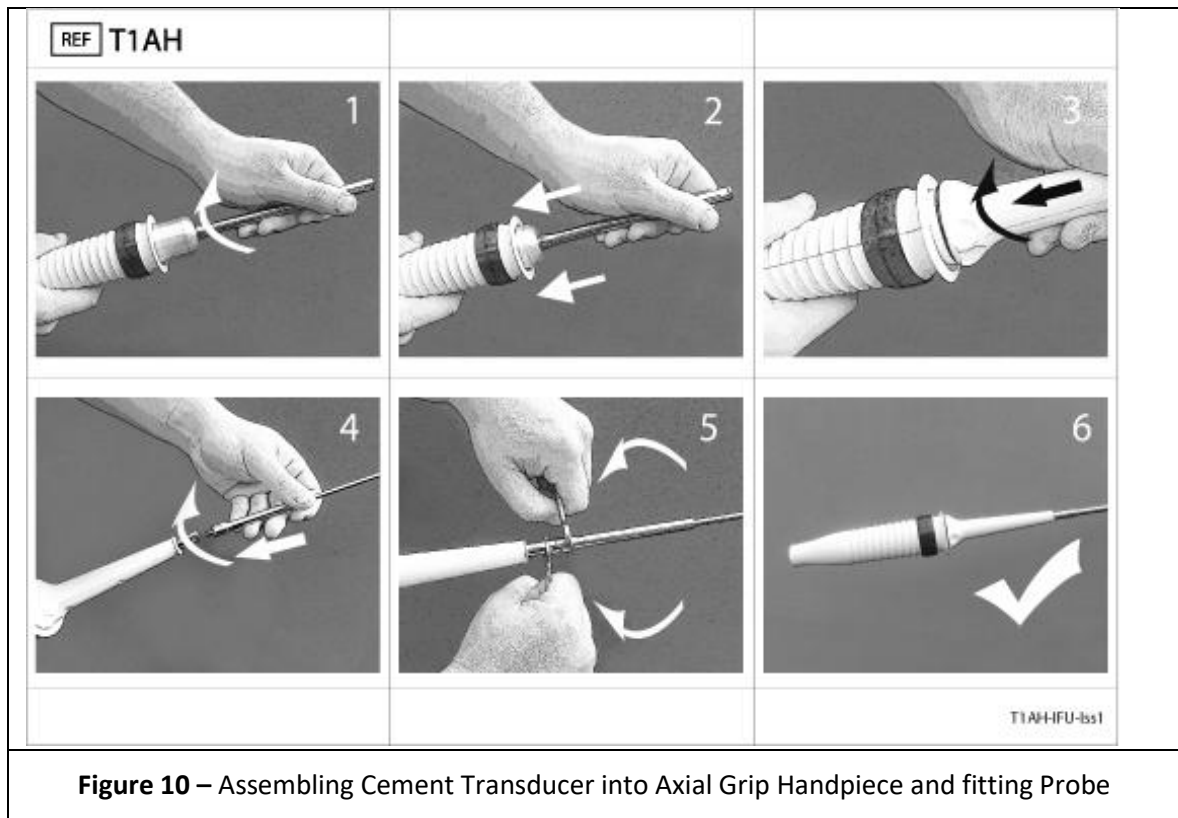

**Optional - Attach the Soft Tissue Transducer (Applied Part)**

- Remove the plug cap by pulling the knurled rings on the plug and the autoclave cap.
- Align the red dot on the metal plug with the red dot on the Generator socket.
- Connect the Transducer to Generator Channel 3.
- Push the plug into the socket until it clicks.
- To remove, pull back on the knurled part of the plug - **Do not** pull the cable.

### Cement Transducer - Connect

- Connect the Cement cable (Yellow coding to Generator Channel 1 or 2 (Yellow rings) by aligning the red dot on the metal plug with the red dot on the Generator socket. Push the plug into the socket until it clicks.
- Connect the other end of the Cement cable (Plastic connector) to the Cement handpiece. Align the arrow on the plastic connector with the spaces separating the two slots in the rear connector on the axial-grip handpiece. Click into place.
- To remove, pull back on the inner part of the plug. Do not pull the cable.

# ARCHIVED COPY:

### Cement Transducer - Initialise

- When the surgeon is ready to use the transducer, they must initialize it to enable power. This is done simply by pressing the black activate button on the handpiece or the yellow footswitch (Ch1 or Ch2). The display shows:

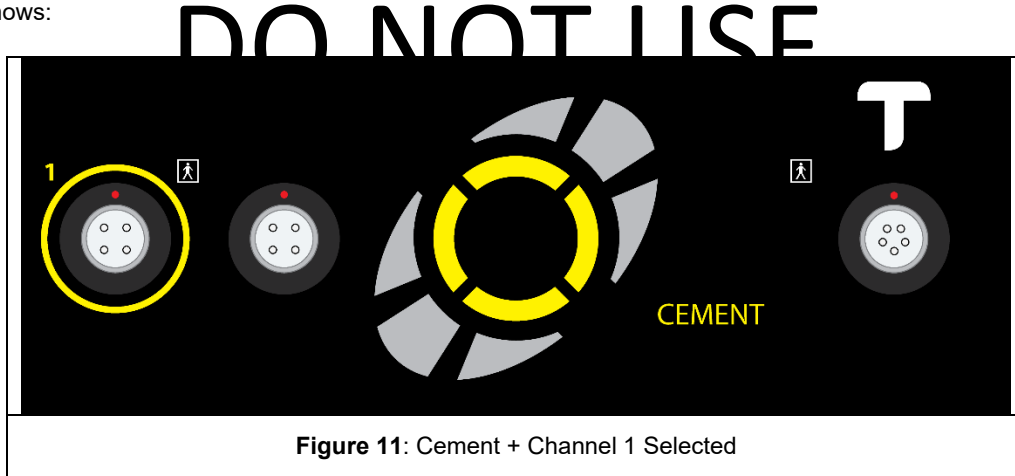

### Cement Transducer - Activate

- Press the black activate button on the Handpiece or the yellow Footswitch. This will activate the Transducer and Probe for surgery. An audible indicator signifies power delivery with a continuous low-pitched tone.

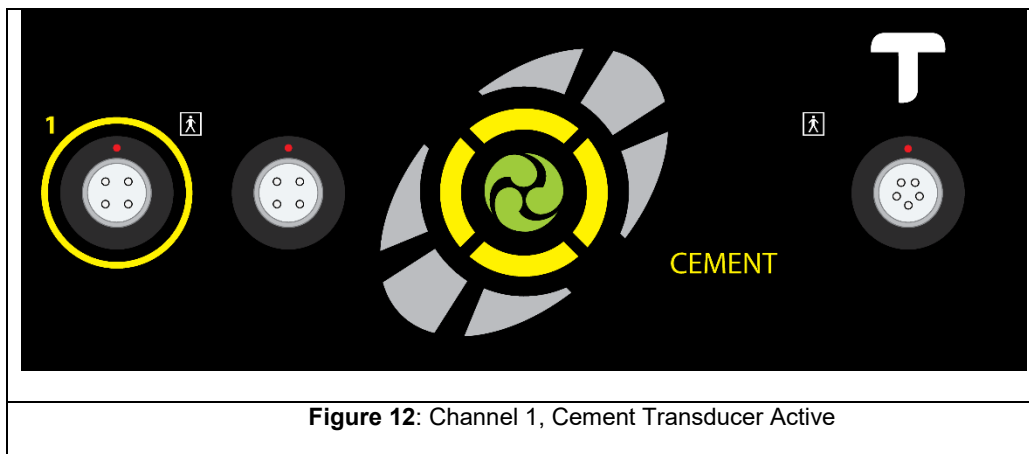

- To stop output, release the Footswitch or activate button.
- If the Footswitch or activate button is held down continuously for 20 seconds the audio indicator sound will change from continuous to pulsed.
- After a further 5 seconds the Generator will terminate power.
  - Output power is cut
  - Audible indicator stops
  - Displays Warning symbol + Transducer symbol + Clock symbol.
- These will remain illuminated as long as the Footswitch or activate button pressed.
- When it is released, normal operation resumes

### Cement Removal – Irrigation

It is important to irrigate the bone canal during the cement removal process for two reasons:- It clears the canal of cement debris, including dust, and it also helps maintain safe operating temperatures within the canal. Such irrigation systems are standard provision in orthopaedic cases.

It is recommended that irrigation in the form of pulsed lavage or manual irrigation is used after each activation of any probe-type, piercer or scraper.

Do not irrigate *during* an activation as this may compromise the efficacy of the ultrasound transmission, translating to a slower cement removal process. The TOR S probes are designed to produce rapid heating at the probe / PMMA interface, thus softening the cement. Any cooling during this process will impede the desired effect.

Any waste products should be disposed of as per normal hospital procedures.

### Fume Extraction

It is recommended that a suitable extraction system is used to remove smoke, aerosols and any associated odors.

Any waste products should be disposed of as per normal hospital procedures.

### Soft Tissue Transducer - Connect

- Plug a Soft tissue transducer into front Channel 3 (Blue ring) by aligning the red dots on the plug and connector receptacle. Push connector and click into place.

### Soft Tissue Transducer – Initialize

- Press the Ch3 grey footswitch to select the channel.
- Audio triple downwards tone.
- Note that it will default to low power (single bar). The display shows:

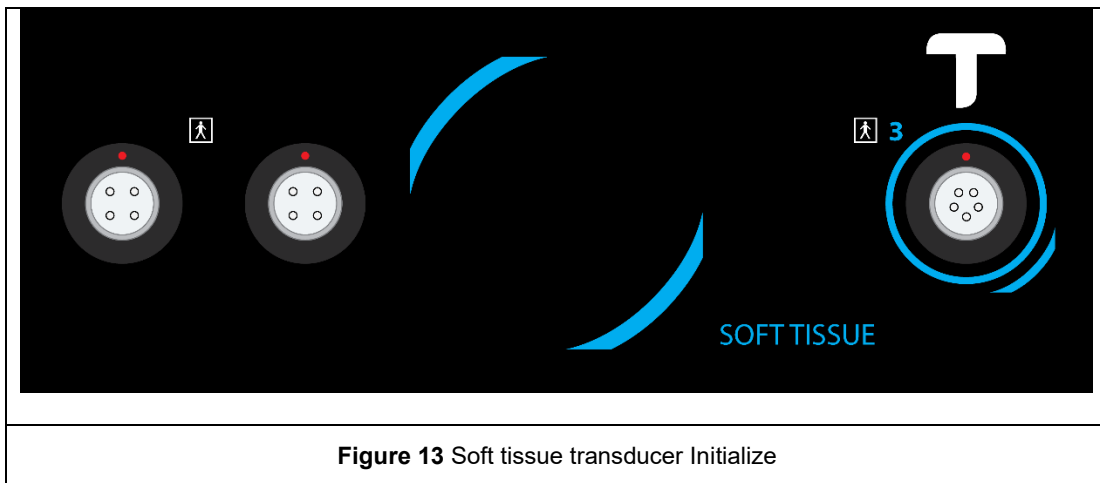

Figure 13 Soft tissue transducer Initialize

### Soft Tissue Transducer – Change Power Level

- If high power is required press the grey Footswitch again.
- Audio triple upwards tone. The display shows:



Figure 14 Soft tissue transducer – high power selected

- Further presses will toggle between low & high power.

### Soft Tissue Transducer – Activate

- Press the Ch3 blue footswitch. This will energize the soft-tissue transducer.
- Audio continuous tone signifies power delivery. Display shows:



Figure 15 Soft tissue transducer active - low power

or



Figure 16 Soft tissue transducer active - high power

Depending upon power level selected.

- To stop output, release the blue footswitch.

- If the footswitch is held down continuously for 20 seconds the audio indicator sound will change from continuous to pulsed.
- After a further 5 seconds the generator will terminate power.
  - Output power is cut
  - Audible indicator stops
  - Displays warning symbol + transducer symbol + clock symbol
- These will remain illuminated as long as the blue footswitch pressed.
- When it is released, normal operation resumes.

**ARCHIVED COPY:**

## Performance Characteristics

- Cement Removal

The different diameters of piercer probes will penetrate cement at different rates but the size range allows access into varying open cement canal diameters with consequent varying volumes of cement removed per "cut".

Likewise, the different scraper probe sizes will remove varying volumes of material per "cut".

The 4 mm piercer (P4R2) is intended specifically for penetrating hard, High-Density Polyethylene (HDPE), cement restrictors (distal plugs). It has no proximal cement trapping flange and will not remove material. Once an initial hole has been made larger piercers and scrapers can be used to erode and remove the plug. It is not recommended for use on the softer, PMMA, or gelatine, distal plugs.

The user should not apply excessive force, but instead, allow the ultrasound to advance the probe through the cement.

PMMA will not cause wear/damage to the probes. If there is evidence of wear/damage on a probe, then this is likely to be caused by the probe making contact with either the bone or a metal obstruction (stem, screw, nail *etc.*)

If the probe heads contact bone, then an audible squeal provides feedback to the user. The user should immediately redirect the probe head to avoid contact with bone. Sometimes the audible response may be damped out when the bone cavity is still densely packed with bone cement, or the user may not be able to hear the very high pitch of the audible feedback from the probe head on bone.

If a TORS Piercer probe appears to be silent but NOT moving forward through material, or making smoke, then it may well be contacting bone. DO NOT CONTINUE TO PUSH without checking where the probe is. Real time X-ray is very effective at this point.

- Soft-Tissue Incision.

The double blade probe head will incise skin and other tissue when pressed lightly but firmly against the target tissue.

The double blade probe head should be drawn through the target tissue, along the line of separation the surgeon requires; successive cuts along this line are used to deepen the incision.









Use Low power for slower cutting and better haemostasis. Use high power for the opposite.



Unlike diathermy the TORS soft-tissue transducer will cut through a surgical rubber glove and into tissue beneath since it is mechanical and NOT relying on a conductive electrical path to supply electric current.

## Turn Off TORS

- Press the black ON/OFF power switch at the rear of the unit. The screen will become entirely black.

**Fault / Warning Indicators: (see also Appendix 4: Tones and Beeps)**

 <p>The Illuminated yellow triangle indicates that a fault has occurred.</p>	<p><b>It will always be accompanied by:</b></p>	
	<p>i. An illuminated symbol indicating the part of the equipment where the fault has occurred</p>	
	<p>ii. Illuminated text instructing the user e.g. Reduce Pressure</p>	
		<p>Or</p>  <p>Or</p>  <p>Or</p> 
	<p>If warning relates to time, the clock symbol also illuminates</p>	
<p>If warning is temperature related the temp symbol also illuminates</p>		

 <p>+</p> 	<p>Soft-tissue transducer lifetime has nearly reached or is over 100%. A high-low tone will sound. Prevents use of the Transducer.</p> <p>NB. Cement transducer lifetime is not monitored</p>
--	---

**FINAL SURGERY**

This will only occur during use.

Soft-tissue transducer lifetime is nearly or over 100%.  
A high-low tone will sound.  
Allows use of transducer for the duration of the current procedure.

**ARCHIVED COPY:**

Note. The working lifetime of the soft-tissue transducer is detailed within the Decontamination section, specifically page 23.

**REDUCE PRESSURE**

**DO NOT USE**

- Too much force is being applied to the TDCR during activation. **Reduce applied force to improve performance.** Excessive force applied during activation can impede cutting performance.
- No transducer connection.
- Probe tip is too hot. **Allow probe tip to cool.**

**RELEASE SWITCH**

Handpiece button or footswitch held in.  
A high-low tone will sound.



Generator has over-heated. Check air vent below generator is unimpeded.  
A high-low tone will sound.  
Try again after 5- 10s.



+



+

**DO NOT USE**

The generator has detected a problem with the connections to the transducer. The warning triangle will illuminate and a triple high-high-high tone will sound and repeat. Switch OFF then ON to clear fault. Re-activate the transducer away from the patient – if fault recurs then change the transducer and return for service.



+



The Generator has detected a problem. The warning triangle will illuminate and a triple high-high-high tone will sound and repeat. Switch OFF then ON to clear fault. Switch generator back on – if fault recurs then return the system for service.

# DECONTAMINATION

In order to replicate the validated decontamination and sterilization processes for the TORS device, Sterilization and Decontamination Units must operate procedures and equipment that conform to ISO 17665-1. Validation of the sterilization process has been completed for steam autoclave cycles with an active phase of 3 minutes at 134°C.

Please refer to the separate Decontamination Certificate and Instruction (W1650006 App1) provided with the Instrument Kit; this document provides all of the details for each of the following subjects:

**ARCHIVED COPY:**

- **After Use Re-Processing**

Immediately after use wipe down all components and remove any surplus body fluids and debris.

After final use some of the cement may remain adhered to the probe distal end, particularly within holes in the Piercer probe heads. This is easily removed by activating the blade in a suspension of fine abrasive grit in water. This is provided with the TORS system in the form of a single use cleaning cell.

**DO NOT USE**

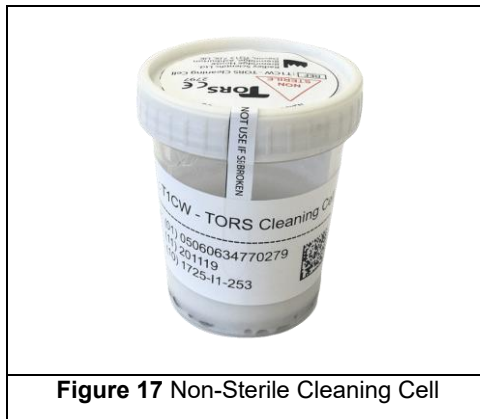

Figure 17 Non-Sterile Cleaning Cell

**IMPORTANT: The cleaning cell is NOT sterile.  
NOT for use DURING procedure**

**ONLY use at the end of the procedure prior to washing and re-sterilization of reusable probes**

Unscrew the cleaning cell lid and pierce the foil seal with the first probe. Activate each used probe in turn in the grit/water suspension in the cleaning cell, swirling the head around in the suspension for 20s. at least. Repeat if necessary. This will remove cement adhered to the surfaces.

Detach the Cement Cable(s) from the Cement Transducer(s) by disconnecting from the handpiece.

Remove the Sleeve from the Grip on the Cement Handpiece. Detach the Handpiece from the Cement Transducer by pulling the Transducer and the Handpiece apart.

Detach the Cement probe from the Cement Transducer using BOTH supplied spanners.

**Do not try to detach the Soft-tissue probe or cable from the Soft Tissue Transducer**

Replace the Transducers, Cables, reusable Probes and spanners back into the autoclave tray, preferably within its original wrap to reduce drying of soil while it is returned to the cleaning facility.

- **Single Use Items**

Dispose of the Cement Handpiece Grip and Sleeve and the Cleaning Cell as per hospital protocols.

- **Reusable Items**

- **Manual Cleaning**

Prepare enzymatic cleaning solution (e.g. Gigazyme Plus) to manufacturer's instructions.

Soak soiled instruments in enzymatic solution for 5 minutes.

When cleaning, fully submerge the instruments in the cleaning solution. Brush with soft non-metallic bristle brush or cloth to remove all traces of blood and debris, concentrating on any crevices, seams, or other surface discontinuities. Clean holes and recesses using an appropriate brush ensuring that the full depth of the feature is reached. Ensure instruments are visibly clean before progressing to the next step.

Rinse instruments thoroughly with clean running water for 2 minutes. Ensure that blind holes and recesses are repeatedly filled and emptied with running water.

Dry instruments immediately after final rinse. Do not exceed 140°C (285°F)

- **Automated Cleaning**

Instruments may require manual cleaning prior to automated cleaning to improve the removal of adherent soil. Brush with a non-metallic bristle brush in enzymatic cleaning solution.

Load instruments such that crevices, seams, surface discontinuities, holes and recesses can drain.

Clean using the "Instruments" cycle in a validated washer disinfectant and a pH neutral cleaning agent intended for use in automatic cleaning (e.g. Getinge Enzymatic Detergent). The cleaning cycle should incorporate pre-rinse, wash, rinse, thermal rinse and drying steps. The duration and temperature of the steps may vary between different washing systems/devices but any washer/disinfectant cycle which is validated to ISO 15883-1, ISO 15883-2 & HTM 01-01 part D is suitable for processing the TORS device(s). Do not exceed 140°C (285°F).

An alkaline cleaning solution such as, for example, Serchem pH Plus Detergent, with a pH up to 13.2 may be used instead of, or in addition to, an enzymatic solution.

- **Cleaning Inspection**

Inspect all instruments prior to sterilization or storage to ensure the complete removal of soiled surfaces.

Visually inspect instruments, if soil is still present clean instruments again.

Inspect cables for wear and damage, ensuring that no cracks, tears, or other damage is found.

Check to see that Probes are free of scratches.

Report any damage found to the Radley Scientific representative.

- **Wrapping**

Double wrap in accordance with local procedures, using standard procedures wrapping techniques such as those described in HTM 01-01 or ANSI/AAMI ST46-1993.

Label contents of wrapped tray using indelible marker or other sterilization compatible label system.

- **Sterilization**

Sterilization is best achieved on the day preceding the surgery, but must be at least one hour prior to use to allow the equipment to cool and stabilize.

△ Transducers are NOT to be submerged in water to expedite cooling.

△ Do NOT sterilize the Generator or Footswitches

These components have been validated for sterilization by the following method in a vacuum autoclave. The parameters for this being 134-137°C (270°- 277°F) for a minimum of 3 and a maximum of 4 minutes. (If national standards dictate autoclaving up to 18 minutes, this is possible but not preferable.)

Next Use - After decontamination, the Transducers, Cement cables, probes and spanners can be re-sterilized as above.

- **End of Life Management**

When a Soft Tissue Transducer has reached the end of its lifetime please contact your local TORS supplier.

TORS generator and all reusable accessories (including Transducers) should be recycled. Contact RSL for return instructions - see end page of this IFO.

**A valid decontamination certificate MUST accompany any returned reusable accessories.**

- **Opened in Error**

In the event of a Single Use Handpiece being unwrapped in error, it may not be re-sterilized.

Care should be taken to ensure that the cables are not kinked during sterilization as this can produce cracks in the cable and reduce cable life.

- **Cleaning the Generator**



The TORS Generator may be cleaned as follows:





- Dilute a neutral pH detergent according to the manufacturer's directions.
- Using above solution, lightly moisten a soft, clean cloth. Wipe surfaces of the Generator.
- Using tap water, lightly moisten a soft, clean cloth. Wipe surfaces of the Generator.
- Dry Generator surfaces with a soft clean cloth.

- **Cleaning the Footswitch**

The TORS Footswitches may be cleaned as follows:

- Dilute a neutral pH detergent according to the manufacturer's directions.
- Using above solution, lightly moisten a soft, clean cloth. Wipe surfaces of the Footswitch.
- Using tap water, lightly moisten a soft, clean cloth. Wipe surfaces of the Footswitch.
- Dry Footswitch surfaces with a soft clean cloth.
- Do not allow any water to enter into the air-hoses.
- Do not detach the air hoses from the Footswitch.

 <p style="text-align: center;"><b>ARCHIVED COPY:</b></p> <p style="text-align: center;"><b>DO NOT USE</b></p>	<p>T1AH - Cement axial grip handpiece (Single Use)</p> <p><b>Supplied sterile (ethylene oxide)</b></p> <p><b>DO NOT USE IF PACKAGING HAS BEEN DAMAGED</b></p>	
<p><b>Figure 18</b> Patient contacting parts supplied sterile</p>		

	<p>T1CT - Cement transducer (Reusable Applied Part)</p>	 <p>These accessories are supplied in a <b>non-sterile condition</b>. The end user must complete decontamination and sterilization processes before use.</p>
	<p>T1TT - Soft tissue transducer + Probe (remains attached for decontamination and reuse) (Reusable Applied Part)</p>	
	<p>T1CC Cement cable (Reusable)</p>	
<p><b>Figure 19</b> Patient contacting parts that must be sterilised</p>		

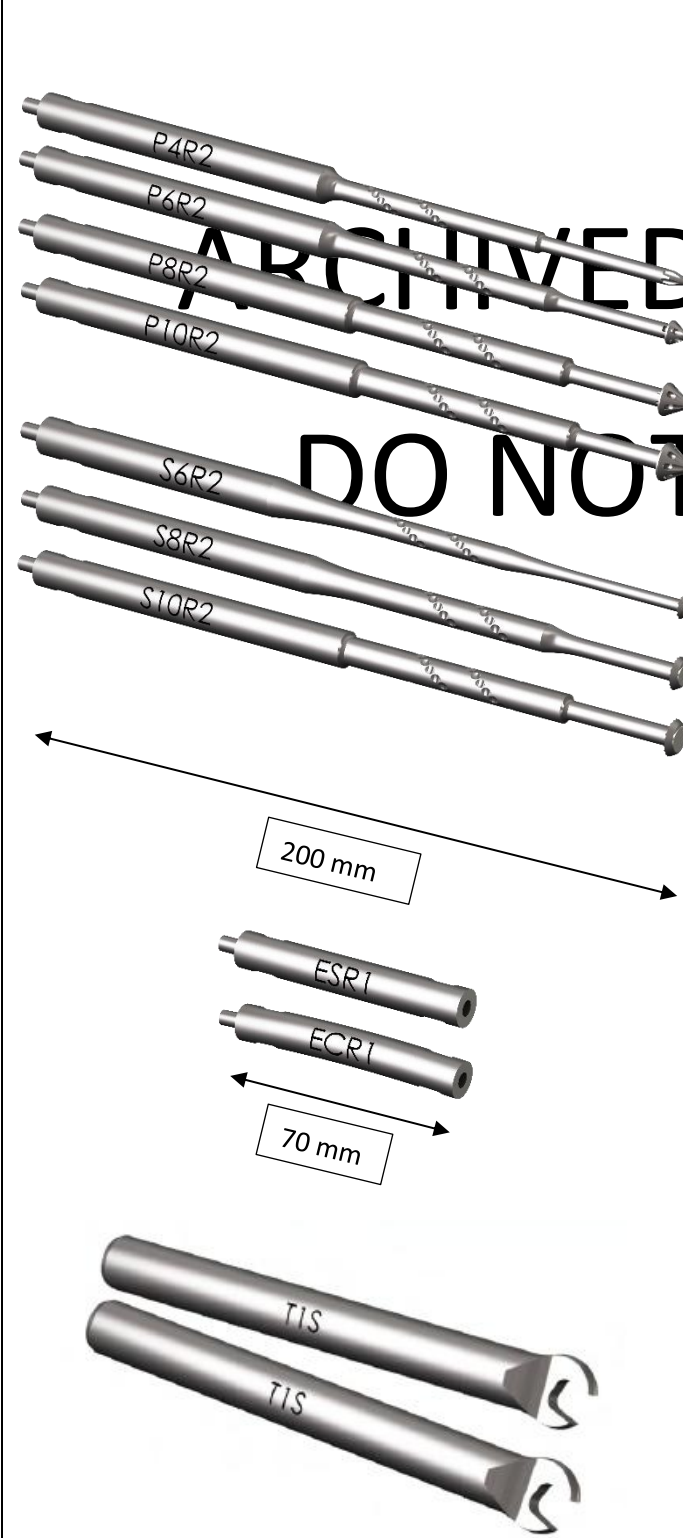

**Cement probes**

**ARCHIVED COPY:**

- P4R2
- P6R2

- P8R2
- P10R2

- S6R2
- S8R2
- S10R2

**Extension bars**

- ESR1
- ECR1

**Spanners**

- T1S
- T1S

(Reusable Applied Parts,  
user sterilized)



These accessories are all supplied in a **non-sterile condition**. The end user must complete decontamination and sterilization processes before use.

OPTIONAL EXTRAS		
	<p><b>Cement probes</b></p> <p>P6R1 P8R1 S6R1 S8R1</p> <p><b>Extension bars</b></p> <p>ESR2 (Reusable Applied Parts, user sterilized)</p>	<p>These accessories are all supplied in a <b>non-sterile condition</b>. The end user must complete decontamination and sterilization processes before use.</p>
<p><b>Figure 19 (continued) Patient contacting parts that must be sterilised</b></p>		

## Equipment Care

### Probe Inspection

Before use all reusable Probes must be inspected for damage.

TORS probes are susceptible to damage if forced into contact with metal (e.g. hand instruments and clamps) when active. The consequence of deformation or scratching a probe is to raise the mechanical stress in the region of the scratch (creating a “stress raiser”) when the probe is vibrating. If the stress is raised sufficiently there is a risk of the probe suffering metal fatigue and cracking. Fatigue failure is more likely if the stress raiser is close to one of the fixed points of maximum mechanical stress in the vibrating probe. If a probe does suffer metal fatigue as a result of a stress raiser causing a crack, the probe will no longer possess a resonant frequency “recognizable” by the generator and cannot be activated by the generator. Report to the supplier any transducer with a probe that has a scratch, if the scratch is deep enough to be detected by sliding a fingernail over it.

### Transducer / Probe Usage

The cement and soft-tissue transducers plus the cement probes of TORS can be decontaminated and reused. This is an important factor in reducing the cost per case. However, they cannot be reused indefinitely as probes will wear and the piezo crystals in transducers will depolarize over time and so service lifetimes are defined within which optimum performance can be expected. Therefore, probes and transducers must be replaced when needed.

The cement transducer lifetime is not limited by the system as its usage time is not monitored by the generator. It should be changed if cutting performance deteriorates. As a guide it may be changed after an average service life of 10 minutes ON-time per case, over 25 cases = 250 minutes ON-time.

All Cement Probes can be used for as long as they continue to soften and remove PMMA effectively as their usage time cannot be monitored by the generator. They should be changed if cutting performance deteriorates. As a guide they may be changed after an average service life of 5 minutes ON-time per case, over 50 cases = 250 minutes ON-time.

For the soft-tissue transducer, every time the generator energizes the transducer, the duration of the activation is counted by the generator then written to a memory chip inside every soft-tissue transducer, overwriting the previous total. When the total activation time reaches pre-set limit for warning or termination, the TORS will alert the user.

The Soft Tissue Transducer can be used until a total activation time of 25 procedures or 250 minutes of ON-time is reached. The lifetime is checked at boot time and during use by the generator. After the lifetime limit is reached a warning message is displayed upon the generator's screen.

### **Storage of Equipment between Cases**

It is recommended that the transducers (with associated cables) are stored, between cases, in a large autoclave tray provided and again, care should be taken to ensure that the cables are not kinked close to the connector.

### **Maintenance**

The hospital is responsible for ensuring that the unit has an electrical safety check performed by qualified service personnel at least once a year.

Do not remove the covers from TORS.

TORS generator does not require periodic calibration. If the generator detects an internal problem, it will display a "Service Due" on the rear LCD. If this is seen, contact RSL to arrange repair.

There are no user-serviceable parts in TORS.

Any damage to the transducers or cables should be reported and the components returned to the supplier at the earliest opportunity.













### **Technical Support**

In line with the company's policy of quality assurance and customer care, RSL offers a telephone helpline service for users of TORS. This is provided by the TORS manufacturer, RSL at its facility in Devon, England.





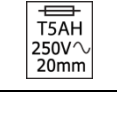
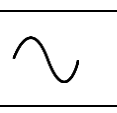

HELPLINE Telephone No. as displayed on the unit is: +44 (0)1364 653899

APPENDICES

Appendix 1: Markings on the TORS front and back panels

	Cement transducer selected
	Soft tissue transducer selected
	Cement transducer output - Channel 1
	Cement transducer output - Channel 2
	Soft tissue transducer output – Channel 3 (low power)
	Soft tissue transducer output – Channel 3 (high power)
	Transducer active
	Model number
	Serial number
	Manufacturer
	Date of manufacture
	FUSE rating – Time delay, 5A, High breaking capacity, 250 Volts AC, size 20mm
100-240V	Mains AC voltage range
	Alternating current
50/60Hz	Mains AC frequency
200VA	Input power
	Warning sign
	Type BF equipment
36kHz	Cement frequency of output





ARCHIVED COPY:  
DO NOT USE





<150W	Cement output power
For Intermittent Use ON/OFF 20/20s	Cement duty cycle
36kHz	Soft issue frequency of output
<50W	Soft tissue output power
For Intermittent Use ON/OFF 3/30s	Soft tissue duty cycle
	Volume
	Footswitch connection
	Equipotential connection
	Output channel
	Follow instructions for use
	Electrical and Electronic equipment. Return waste to a collection system or treatment and recycling facilities. Follow decontamination instructions before returning waste.
	General caution sign

ARCHIVED COPY:

DO NOT USE





## Appendix 2: Labelling Symbols Glossary

Symbol	Standard	Ref #	Title	Description
	ISO 15223-1 Medical devices — Symbols to be used with information to be supplied by the manufacturer	5.1.1	Manufacturer	Indicates the medical device manufacturer
	ISO 15223-1 Medical devices — Symbols to be used with information to be supplied by the manufacturer	5.1.2	Authorized representative in the European Community/ European Union	Indicates the authorized representative in the European Community/ European Union
	ISO 15223-1 Medical devices — Symbols to be used with information to be supplied by the manufacturer	5.1.3	Date of manufacture	Indicates the date when the medical device was manufactured
	ISO 15223-1 Medical devices — Symbols to be used with information to be supplied by the manufacturer	Permitted by standard	Country of manufacture	Used in place of 5.1.3 and will have date of manufacture nearby.  Indicates that the product was manufactured in Great Britain (also known as the UK or United Kingdom of Great Britain and Northern Ireland)

	<p>ISO 15223-1 Medical devices — Symbols to be used with information to be supplied by the manufacturer</p>	<p>5.1.4</p>	<p>Use-by date</p>	<p>Indicates the date after which the medical device is not to be used</p>
	<p>ISO 15223-1 Medical devices — Symbols to be used with information to be supplied by the manufacturer</p>	<p>5.1.5</p>	<p>Batch code</p>	<p>Indicates the manufacturer's batch code so that the batch or lot can be identified</p>
	<p>ISO 15223-1 Medical devices — Symbols to be used with information to be supplied by the manufacturer</p>	<p>5.1.6</p>	<p>Catalogue number</p>	<p>Indicates the manufacturer's catalogue number so that the medical device can be identified.</p>
	<p>ISO 15223-1 Medical devices — Symbols to be used with information to be supplied by the manufacturer</p>	<p>5.1.7</p>	<p>Serial number</p>	<p>Indicates the manufacturer's serial number so that a specific medical device can be identified</p>
	<p>ISO 15223-1 Medical devices — Symbols to be used with information to be supplied by the manufacturer</p>	<p>5.1.8</p>	<p>Importer</p>	<p>Indicates the entity importing the medical device into the locale</p>

CHIVED COPY:

DO NOT USE

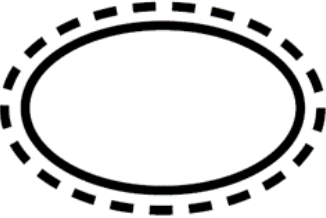
	<p>ISO 15223-1 Medical devices — Symbols to be used with information to be supplied by the manufacturer</p>	<p>5.1.9</p>	<p>Distributor</p>	<p>Indicates the entity distributing the medical device into the locale</p>
	<p>ISO 15223-1 Medical devices — Symbols to be used with information to be supplied by the manufacturer</p>	<p>5.2.3</p>	<p>Sterilized using ethylene oxide</p>	<p>Indicates a medical device that has been sterilized using ethylene oxide.</p>
	<p>ISO 15223-1 Medical devices — Symbols to be used with information to be supplied by the manufacturer</p>	<p>5.2.7</p>	<p>Non-sterile</p>	<p>Indicates a medical device that has not been subjected to a sterilization process</p>
	<p>ISO 15223-1 Medical devices — Symbols to be used with information to be supplied by the manufacturer</p>	<p>5.2.8</p>	<p>Do not use if package is damaged and consult instructions for use</p>	<p>Indicates a medical device that should not be used if the package has been damaged or opened and that the user should consult the instructions for use for additional information.</p>
	<p>ISO 15223-1 Medical devices — Symbols to be used with information to be supplied by the manufacturer</p>	<p>5.2.14</p>	<p>Single sterile barrier system with protective packaging outside</p>	<p>Indicates a single sterile barrier system with protective packaging outside</p>



ISO 15223-1  
Medical devices  
— Symbols to  
be used with  
information to  
be supplied by  
the  
manufacturer

Permitted  
by  
standard

Combines 5.2.3  
and 5.2.14 (As  
permitted by ISO  
15223-1) to  
indicate that the  
device is  
sterilized by  
ethylene oxide  
and has a single  
sterile barrier with  
protective  
packaging  
outside

**ARCHIVED COPY:  
DO NOT USE**



ISO 15223-1  
Medical devices  
— Symbols to  
be used with  
information to  
be supplied by  
the  
manufacturer

5.3.4

Keep dry

Indicates a  
medical device  
that needs to be  
protected from  
moisture.

**NOTE:** This  
symbol indicates  
that the  
packaging must  
be kept dry to  
maintain the  
integrity of the  
packaging  
material. The  
device itself is  
designed for use  
in wet or fluid-  
filled  
environments and  
is not affected by  
moisture.







ISO 15223-1  
Medical devices  
— Symbols to  
be used with  
information to  
be supplied by  
the  
manufacturer

5.3.7

Temperature  
limit



Indicates the  
temperature limits  
to which the  
medical device  
can be safely  
exposed.





	<p>ISO 15223-1 Medical devices — Symbols to be used with information to be supplied by the manufacturer</p>	<p>5.3.8</p>	<p>Humidity limitation</p>	<p>Indicates the range of humidity to which the medical device can be safely exposed.</p>
	<p>ISO 15223-1 Medical devices — Symbols to be used with information to be supplied by the manufacturer</p>	<p>5.4.2</p>	<p>Do not re-use/ Single use only</p>	<p>Indicates a medical device that is intended for one single use only.</p>
	<p>ISO 15223-1 Medical devices — Symbols to be used with information to be supplied by the manufacturer</p>	<p>5.4.3</p>	<p>Consult instructions for use</p>	<p>Indicates the need for the user to consult the instructions for use.</p>
	<p>ISO 15223-1 Medical devices — Symbols to be used with information to be supplied by the manufacturer</p>	<p>5.4.4</p>	<p>Caution</p>	<p>Indicates the need for the user to consult the instructions for use for important cautionary information such as warnings and precautions that cannot, for a variety of reasons, be presented on the medical device itself.</p>

**PHIVED COPY:  
DO NOT USE**

ARCHIVED COPY:

ON NOT USE

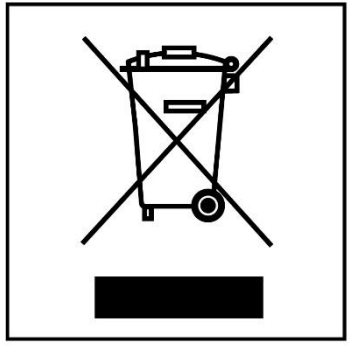
	<p>ISO 15223-1 Medical devices — Symbols to be used with information to be supplied by the manufacturer</p>	<p>5.7.7</p>	<p>Medical Device</p>	<p>Indicates the item is a medical device.</p>
	<p>ISO 15223-1 Medical devices — Symbols to be used with information to be supplied by the manufacturer</p>	<p>5.7.10</p>	<p>Unique Device Identifier</p>	<p>Indicates a carrier that contains Unique Device Identifier information.</p>
	<p>ISO 7010-M002, IEC 60601-1, Table D.2, Symbol 10</p>		<p>Follow instructions for use or follow electronic instructions for use.</p>	<p>Follow instructions for use.</p>
	<p>MDD 93/42/EEC MDR 2017/745 Regulation (EC) 765/2008</p>	<p>Annex XII Article 20 Annex II</p>	<p>CE marking, may include Notified Body Reference no. 2797</p>	<p>Signifies European technical conformity.</p>
				<p>Signifies UKCA technical conformity</p>

	<p>21 CFR 801.15 21 CFR 801.109</p>	<p>(c) (1) (i) (F) (b) (1)</p>	<p>Prescription only</p>	<p>Caution: Federal (US) law restricts this device to sale by or on the order of a physician.</p>
	<p>ISO 5225-1 Medical devices — Symbols to be used with information to be supplied by the manufacturer</p>	<p>A16</p>	<p>Consult instructions for use or consult electronic instructions for use</p>	
				<p>Global Trade Item Number</p>
	<p>Directive 2002/96/ EC (repealed).  Replaced by DIRECTIVE 2012/19/EU which does NOT contain this symbol.</p>		<p>Waste stream disposal status</p>	<p>Do not dispose of electronic products in the general waste stream</p>
	<p>DIRECTIVE 2012/19/ EU (WEEE)</p>	<p>Annex IX</p>	<p>Collect separately</p>	<p>indicating separate collection for EEE</p>
 <p>800526</p>				<p>SGS North America Certification Mark</p>

ARCHIVED COPY  
DO NOT USE

## Appendix 3: Electromagnetic Interference

Table 1

Guidance and manufacturer's declaration – electromagnetic emissions			
TORS T1G is intended for use in the electromagnetic environment specified below. The customer or the user of TORS should assure that it is used in such an environment.			
Emissions Test	Compliance	Electromagnetic environment - guidance	
RF emissions CISPR 11	Group 1	TORS uses RF energy only for its internal function. Therefore, its RF emissions are very low and are not likely to cause any interference in nearby electronic equipment.  TORS is suitable for use in all establishments other than domestic and those directly connected to the public low-voltage power supply network that supplies buildings used for domestic purposes.	
RF emissions CISPR 11	Class A		
Harmonic emissions IEC 61000-3-2	No testing – not connected to public mains network		
Voltage fluctuations /flicker emissions IEC 61000-3-3	No testing – not connected to public mains network		

Table 2

Guidance and manufacturer's declaration – electromagnetic immunity			
TORS is intended for use in the electromagnetic environment specified below. The customer or the user of TORS should assure that it is used in such an environment.			
IMMUNITY test	IEC 60601 test level	Compliance level	Electromagnetic environment - guidance
Electrostatic discharge (ESD) IEC 61000-4-2	±8 kV contact ±15 kV air	±6 kV contact ±8 kV air (1)	Floors should be conductive. No synthetic material should be used in the environment. The relative humidity should be in the range 40% to 60%.
Electrical fast transient/burst IEC61000-4-4	±2 kV for power supply lines	±2 kV for power supply lines	Mains power quality should be that of a typical commercial or hospital environment.
Surge IEC 61000-4-5	±1 kV differential mode ± 2 kV common mode	±1 kV differential mode ± 2 kV common mode	Mains power quality should be that of a typical commercial or hospital environment.
Voltage dips, short interruptions and voltage variations on power supply input lines IEC 61000-4-11	0 % $U_T$ <sup>(2)</sup> (100 % dip in $U_T$ ) for 0.5 cycle at: 0°,45°,90°, 135°,180°,225°, 270°,315°  0 % $U_T$ (100 % dip in $U_T$ ) for 1 cycles  70 % $U_T$ (30 % dip in $U_T$ ) For 25/30 cycles  0 % $U_T$ (100 % interrupt in $U_T$ ) for 250/300 cycles	0 % $U_T$ (100 % dip in $U_T$ ) for 0.5 cycle at: 0°,45°,90°, 135°,180°,225°, 270°,315°  0 % $U_T$ (100 % dip in $U_T$ ) for 1 cycles  70 % $U_T$ (30 % dip in $U_T$ ) For 25/30 cycles  0 % $U_T$ (100 % interrupt in $U_T$ ) for 250/300 cycles	Mains power quality should be that of a typical commercial or hospital environment. If the user of TORS requires continued operation during power mains interruptions, it is recommended that TORS be powered from an uninterruptible power supply.
Power frequency (50/60 Hz) magnetic field IEC61000-4-8	3 A/m	No testing	No magnetically sensitive components.
<b>NOTES:</b> Mitigation applied because of environment. $U_T$ is the a.c. mains voltage prior to application of the test level.			

Table 3

Guidance and manufacturer's declaration – electromagnetic immunity			
TORS is intended for use in the electromagnetic environment specified below. The customer or the user of TORS should assure that it is used in such an environment.			
IMMUNITY test	IEC 60601 test level	Compliance level	Electromagnetic environment - disturbance
Conducted RF IEC 61000-4-6	3V rms 150kHz to 80 MHz Outside ISM bands	3V rms	Portable and mobile RF communications equipment should be used no closer to any part of TORS, including cables, than the recommended separation distance calculated from the equation applicable to the frequency of the transmitter.  Recommended separation distance $d = 1.2\sqrt{P}$ , 150 kHz to 80 MHz $d = 1.2\sqrt{P}$ , 80MHz to 800MHz $d = 2.3\sqrt{P}$ , 800MHz to 2.3GHz
	6V rms In ISM bands 0.15MHz to 80MHz 80% AM at 1kHz	6V rms	where P is the maximum power output rating of the transmitter in watts (W) according to the transmitter manufacturer and d is the recommended separation distance in metres (m).
Radiated RF IEC 61000-4-3	3 V/m 80MHz to 2.5GHz	3 V/m	Field strengths from fixed RF transmitters, as determined by an electromagnetic site survey, <sup>a</sup> should be less than the compliance level in each frequency range. <sup>b</sup>
	9 V/m 710MHz, 745MHz, 780MHz, 5240MHz, 5500MHz, 5785MHz	9V/m	Interference may occur in the vicinity of equipment marked with the following symbol.
Immunity to proximity fields from RF wireless communications equipment	27 V/m 385MHz	27V/m	
	28 V/m 450MHz, 810MHz, 870MHz, 930MHz, 1720MHz, 1845MHz, 1970MHz, 2450MHz	28V/m	
NOTE 1 At 80 MHz and 800 MHz, the higher frequency range applies			
NOTE 2 These guidelines may not apply in all situations. Electromagnetic propagation is affected by absorption and reflection from structures, objects and people.			
<p><i>a Field strength from fixed transmitters, such as base stations for radio (cellular/cordless) telephones and land mobile radios, amateur radio, AM and FM radio broadcast and TV broadcast cannot be predicted theoretically with accuracy. To assess the electromagnetic environment due to fixed RF transmitters, an electromagnetic site survey should be considered. If the measured field strength in the in the location in which TORS is used exceed the applicable RF compliance level above, TORS should be observed to verify normal operation. If abnormal performance is observed, additional measures may be necessary, such as re-orienting or relocating TORS.</i></p>			
<p><i>b Over the frequency range 150 kHz to 80 MHz, field strengths should be less than 3 V/m</i></p>			

**Table 4**

Recommended separation distances between portable and mobile RF communications equipment and TORS			
TORS is intended for use in an electromagnetic environment in which radiated RF disturbances are controlled. The customer or the user of TORS can help prevent electromagnetic interference by maintaining a minimum distance between portable and mobile RF communications equipment and TORS as recommended below, according to the maximum output power of the communications equipment.			
Rated maximum output power of transmitter	Separation distance according to frequency of transmitter		
	150 kHz to 80 MHz	80 MHz to 800 MHz	800MHz to 2.5 GHz
	$d = 1.2\sqrt{P}$	$d = 1.2\sqrt{P}$	$d = 2.3\sqrt{P}$
0.01	0.12	0.12	0.23
0.1	0.38	0.38	0.73
1	1.2	1.2	2.3
10	3.8	3.8	7.3
100	12	12	23
For transmitters rated at a maximum output power not listed above, the recommended separation distance <i>d</i> in metres (m) can be estimated using the equation applicable to the frequency of the transmitter, where <i>P</i> is the maximum output power rating of the transmitter in watts (W) according to the transmitter manufacturer.			
NOTE 1 At 80 MHz and 800 MHz, the higher frequency range applies			
NOTE 2 These guidelines may not apply in all situations. Electromagnetic propagation is affected by absorption and reflection from structures, objects and people.			

ARCHIVED COPY:

DO NOT USE

**Appendix 4: Tones and Beeps**

Rising flourish	TORS is booting to standby mode
No Tone	TORS is in standby mode
Triple tone – low-medium-low pitch	Handpiece activate button has been pressed to initialize handpiece (cement) Grey footswitch toggle pad has been pressed to initialize soft-tissue Ch3
Continuous low pitched tone	Acoustic output for the cement transducer Acoustic output at the LOW power level for the soft-tissue transducer
Continuous high pitched tone	Acoustic output at the HIGH power level for the soft-tissue transducer
Triple tone – low-medium-high pitch	Soft tissue transducer is changing from LOW to HIGH power
Triple tone – high-medium-low pitch	Soft tissue transducer is changing from HIGH to LOW power
Double beep –high>low pitch	The Generator has reset itself after a minor problem such as time-out or over-temperature but the most common event is frequency mis-tuning due to probe over-damping. So, generally this tone means:  "Over-loaded probe, reduce pressure and try again"
Triple beep – high>high>high pitch	A more serious problem has been detected.

## Appendix 5: Rear Panel Messages

The LCD on the rear panel will display messages that indicate the status of the equipment. The following table shows the possible displays:

Message	Status	Action required
Radley Scientific Ltd TORS Issue x	Start up message. Shows the Issue number of the software "X"	Now awaiting transducer to be plugged in
Cement / Soft Tissue Ready	The mode switch has been operated and the relevant transducer is ready to be activated	Now awaiting use
36500Hz Low Power	Low power is selected (STT Only) (via Soft tissue footswitch)	No action required
36500Hz High Power	High power is selected (STT Only) (via Soft tissue footswitch)	
36000Hz Cement Active OR Soft Tissue Active	While transducer is active the top line will show the frequency. After releasing the switch it will display the final running frequency.	No action required
Active Too long Release Switches	The active button has been held on for too long. No output.	Release activate button on handpiece or on footswitch
Release Switches	Either activate or toggle button (or Footswitches) has been pressed at switch on.	Release activate or toggle button when switching on generator
Check Transducer Ease Grip and Retry	Transducer has been loaded too heavily	Release switch, then reactivate using less pressure on the jaw
	Transducer is too hot.	Allow transducer to cool.
Transducer Limit	Transducer is approaching 100% lifetime. Final use. <b>ONLY APPLIES TO T1TT</b>	Replace transducer after use <b>ONLY APPLIES TO T1TT</b>
Change Tdcr Transducer Limit	Transducer has reached 100% lifetime and must be replaced. <b>ONLY APPLIES TO T1TT</b>	Replace transducer <b>ONLY APPLIES TO T1TT</b>
Transducer Limit Ready		
Change Transducer Restart	Transducer frequency too low and feedback signal is low.	Switch supply off & on. Replace transducer if seen 3 times.
Transducer Leakage Change Tdcr	Generator has detected voltage on the transducer.	Switch supply off & on. Replace transducer if seen 3 times.
Frequency Error Service due	The generator has detected a serious internal problem.	Switch supply off & on. If message seen again generator requires service.

## Appendix 6: Technical Specification

Model Nos:	See Appendix 2
Dimensions:	Generator: 340 mm (width) x 95 mm (height) x 375 mm (depth) 13.4" (width) x 3.7" (height) x 13.4" (depth)
Weight:	Generator: 7.6 kg Transport case: 13.8 kg (loaded with generator) Transducer: 0.37 kg
Fuse Type:	T5A, 250 V, 20 mm (2 off)
Cordset	Contact RSL for recommended type
Power supply input	100V – 240 V, 50/60 Hz
Power consumption	200 VA
Cement Output - Frequency of operation	36k Hz
Cement Output – Power	<150 W
Cement Mode of Operation	Intermittent ON/OFF, 20/20 s
Cement Transducer Classification:	Type BF
Soft Tissue Output - Frequency of operation	36k Hz
Soft Tissue Output – Power	<50 W
Soft Tissue Mode of Operation	Intermittent ON/OFF, 3/30 s
Soft Tissue Transducer Classification:	Type BF
Insulation Classification	Generator: Class 1
Transducer	Titanium, stainless steel, and plastic.

	Autoclavable maximum 50 cycles for the Soft-Tissue Transducer and the Cement Transducer.
Environment for Transportation & Storage: (Except T1AH – Sterile Handpiece)	Temperature: -10°C to +50°C Relative humidity: 10% to 90% Atmospheric pressure: 50 kPa to 106 kPa
Environment for Storage of T1AH Sterile Handpiece:	Temperature: +10°C to +35°C Relative humidity: 30% to 50% Atmospheric pressure: 50 kPa to 106 kPa
Environment for Use:	Temperature: +10°C to +30°C Relative humidity: 20% to 70% Atmospheric pressure: 81 kPa to 106 kPa

**ARCHIVED COPY:**

TORS has been designed and built-in accordance with ISO 13485: 2016 Quality Assurance standard for medical devices.

CE conformance has been certified and the equipment complies with:

**DO NOT USE**

EN 60601-1:2005 + COR.1:2006 + CORR.2:2007 + A1:2012  
EN 60601-1:2006 + A11:2011 + A1:2013  
ANSI/AAMI ES60601-1:2005/ (R) 2012

## Appendix 7: Warranty Statement

Subject to the terms and conditions listed in the warranty document (available on request), Radley Scientific Ltd. guarantees to replace or repair free of charge any defective parts of TORS notified within the warranty period. This applies to the hardware associated with TORS 1 for the purposes of warranty claims made by any party supplied directly by the Company or its authorized representative.

ARCH COPY:  
DO NOT USE

CE  
2797

UK  
CA  
0086



Bremridge House,  
Bremridge,  
Ashburton  
S. Devon  
TQ13 7JX  
UK

Tel: +44 (0)1364 653899 – Helpline

[www.tors.co.uk](http://www.tors.co.uk)

endocon GmbH  
In der Au 5  
Wiesenbach  
69257  
Germany

Effectum CH-REP AG  
Kirchgasse 11  
CH-4600 Olten